

BRACKET BH19

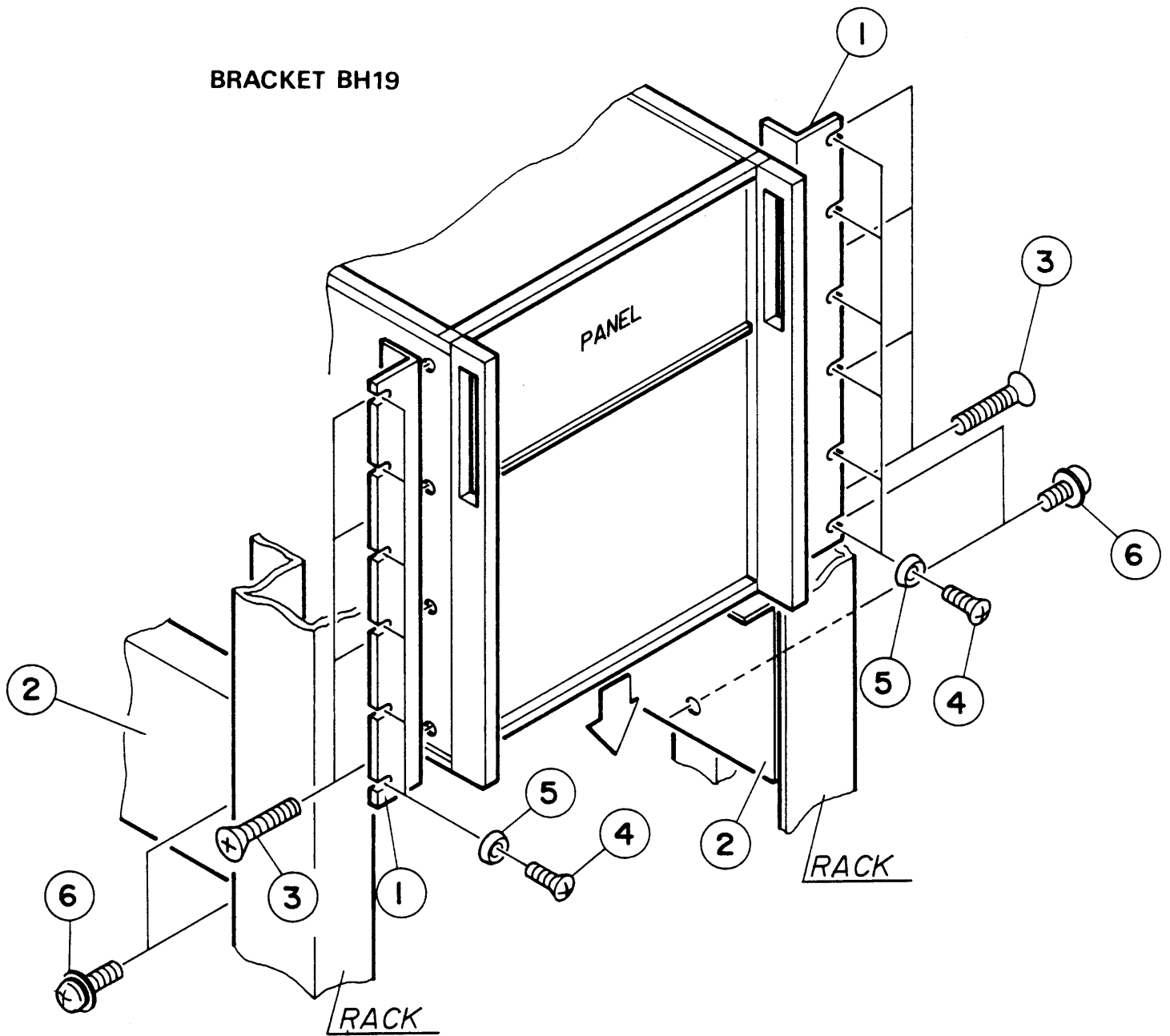

NO.	DESCRIPTION	QTY	CODE NO.
1	BRACKET BH19	2	D3-984-401
2	STAY FOR BH19	2	D3-984-402
3	SCREW,FLAT HEAD M6x1x25 S-ZN	8	M2-001-213
4	SCREW,OVAL HEAD M5x0.8x14 B-NI	12	M2-002-091
5	FINISHING WASHER 5CW	12	M5-003-031
6	SCREW WITH SW,PW M5x0.8x10 S-ZN	8	M3-012-131